

Terminal Block Relays



Contents

Description

Terminal Block Relays

Standard Terminal Block Relays	V7-T3-4
OptoCoupler Terminal Block Relays	V7-T3-12
High Current Terminal Block Relays	V7-T3-15
XR Series Accessories	V7-T3-18

Page

Catalog Number Selection

XR Series—Overview

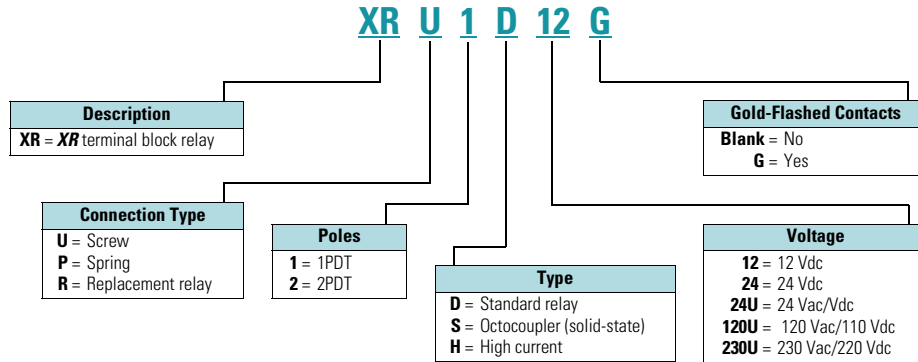

Standard Terminal Block Relay



Contents

Description	Page
Standard Terminal Block Relays	
Product Selection	V7-T3-5
Technical Data and Specifications	V7-T3-6
Electrical Schematics	V7-T3-11
Dimensions	V7-T3-11
OptoCoupler Terminal Block Relays	V7-T3-12
High Current Terminal Block Relays	V7-T3-15
XR Series Accessories	V7-T3-18

Standard Terminal Block Relays

Product Description

The **XR** Series Terminal Block Relays are ideal for applications that require a high switching capacity and long electrical service life. The relays are plug-in interfaces that connect to basic terminal blocks. The **XR** Series uses screw or spring-cage technology, as well as offers quick system wiring, superior safety features, clear labeling and a high level of modularity.

Application Description

Used in automation systems, electromechanical relays guarantee a safe connection between process I/O and electronic controls. The following functions are covered by relay coupling elements:

- Electrical isolation between the input and output circuits
- Independence of the type of switching current (AC and DC)
- High short-term overload resistance in the event of short circuits or voltage peaks
- Low switching losses
- Ease of operation

Features

- Pluggable relay allows for field replacement
- Functional plug-in bridges
- Choice of screw connections or spring-cage connection
- LED status indication
- DIN rail mount
- Only 6.2 mm wide for single-pole versions, 14 mm wide for double-pole
- All common input voltages between 12 Vdc to 120 Vac
- Gold-plated contacts available
- Equipped with a robust, miniature relay:
 - IP67 protection
 - Environmentally friendly, cadmium-free contact material
 - Easy, cost-effective installation and replacement using the engagement lever

Standards and Certifications

- cULus listed
- CE



Product Selection

XRU1D 24U



Standard Terminal Block Relays

Gold-Plated Contacts	Rated Current	Supply Voltage	Standard Pack	Catalog Number
1PDT Screw Connection				
No	6 A	12 Vdc	10	XRU1D12
No	6 A	120 Vac/110 Vdc	10	XRU1D120U
Yes	6 A	120 Vac/110 Vdc	10	XRU1D120UG
No	6 A	24 Vdc	10	XRU1D24
No	6 A	24 Vac/Vdc	10	XRU1D24U
Yes	6 A	24 Vac/Vdc	10	XRU1D24UG
No	6 A	230 Vac/220 Vdc	10	XRU1D230U
1PDT Spring Cage Connection				
No	6 A	12 Vdc	10	XRP1D12
No	6 A	120 Vac/110 Vdc	10	XRP1D120U
No	6 A	24 Vdc	10	XRP1D24
No	6 A	24 Vac/Vdc	10	XRP1D24U
No	6 A	230 Vac/220 Vdc	10	XRP1D230U
DPDT Screw Connection				
No	6 A	12 Vdc	10	XRU2D12
No	6 A	120 Vac/110 Vdc	10	XRU2D120U
No	6 A	24 Vdc	10	XRU2D24
No	6 A	24 Vac/Vdc	10	XRU2D24U
No	6 A	230 Vac/220 Vdc	10	XRU2D230U

Standard Replacement Relays

Gold-Plated Contacts	Rated Current	Supply Voltage ^①	Standard Pack	Catalog Number
1PDT				
No	6 A	12 Vdc	10	XRR1D12
No	6 A	120 Vac/110 Vdc	10	XRR1D120U
Yes	6 A	120 Vac/110 Vdc	10	XRR1D120UG
No	6 A	24 Vdc	10	XRR1D24
Yes	6 A	24 Vdc	10	XRR1D24G
DPDT				
No	6 A	12 Vdc	10	XRR2D12
No	6 A	120 Vac/110 Vdc	10	XRR2D120U
No	6 A	24 Vdc	10	XRR2D24
No	6 A	230 Vac/220 Vdc	10	XRR2D230U

Note

^① Voltage is the rating at the base. It may not match the voltage on the specific replacement relay.

Standard DPDT Screw Connection Terminal Block Relays

Catalog Number Replacement Relay	XRU2D12 XRR2D12	XRU2D24 XRR2D24	XRU2D24U XRR2D24	XRU2D120U XRR2D120U
Input voltage	12 Vdc	24 Vdc	24 Vac/Vdc	120 Vac/110 Vdc
Connection Data				
Rigid solid AWG (mm ²)	26–14 (0.14–2.5)	26–14 (0.14–2.5)	26–14 (0.14–2.5)	26–14 (0.14–2.5)
Flexible stranded AWG (mm ²)	26–14 (0.14–2.5)	26–14 (0.14–2.5)	26–14 (0.14–2.5)	26–14 (0.14–2.5)
Input Data for 1PDT Spring Cage Versions				
Input voltage	12 Vdc	24 Vdc	24 Vac/Vdc	120 Vac/110 Vdc
Permissible range	See Page V7-T3-10	See Page V7-T3-10	See Page V7-T3-10	See Page V7-T3-10
Typical input current	33 mA	18 mA	17.5 mA	4.5 mA (120 Vac)/4.2 mA (110 Vdc)
Typical response time	8 ms	8 ms	8 ms	7 ms
Typical release time	10 ms	10 ms	10 ms	10 ms
Input protection	Polarity protection diode, free-wheeling diode	Polarity protection diode, free-wheeling diode	Bridge rectifier	Bridge rectifier
Output Data				
Contact type	2PDT	Single contact, 2PDT	Single contact, 2PDT	Single contact, 2PDT
Contact material	AgNi	AgNi	AgNi	AgNi
Max. switching voltage	250 Vac/Vdc ^①	250 Vac/Vdc ^①	250 Vac/Vdc ^①	250 Vac/Vdc ^①
Min. switching voltage	5 V	5 V	5 V	5 V
Limiting continuous current	6 A	6 A	6 A	6 A
Max. inrush current	15 A (300 ms)	15 A (300 ms)	15 A (300 ms)	15 A (300 ms)
Min. switching current	10 mA	10 mA	10 mA	10 mA
Min. switching power	50 mW	50 mW	50 mW	50 mW
General Data				
Ambient temp range	–4 °F to +140 °F (–20 °C to +60 °C)	–4 °F to +140 °F (–20 °C to +60 °C)	–4 °F to +140 °F (–20 °C to +60 °C)	–4 °F to +140 °F (–20 °C to +60 °C)
Rated operating mode	100% operating factor	100% operating factor	100% operating factor	100% operating factor
Inflammability class	V0, in accordance with UL 94	V0, in accordance with UL 94	V0, in accordance with UL 94	V0, in accordance with UL 94
Mechanical service life	3 x 10 ⁷ cycles	3 x 10 ⁷ cycles	3 x 10 ⁷ cycles	3 x 10 ⁷ cycles

Note

^① The separating plate, XRAPLCEK, should be installed for voltages greater than 250 V (L1, L2, L3) between identical terminal points of adjacent modules. Potential bridging is then possible with the XRFBST bridge system.